

Creek CD43 mk 2

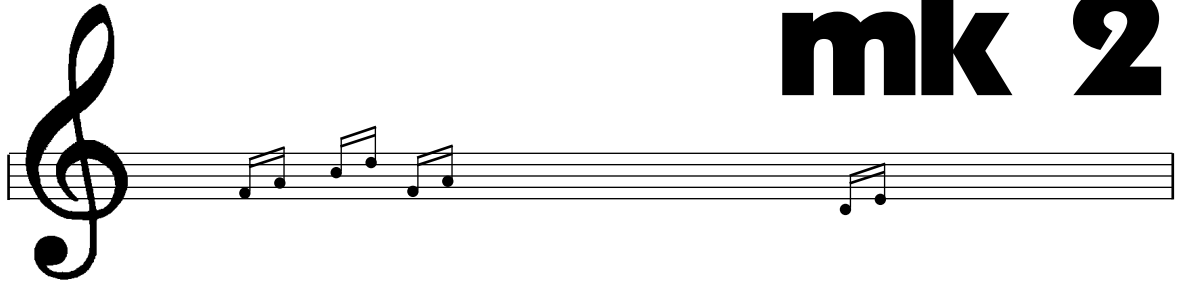

Compact Disc Player



Operating Instructions

CONGRATULATIONS ON YOUR PURCHASE

Your new CD43 mk2 Compact Disc Player is designed to provide maximum enjoyment and years of trouble free service. If this is your first CD player, you will find the compact disc system a major step forward in the science of audio technology. By employing the most sophisticated digital and optical technologies, the compact disc not only offers the ultimate in sound reproduction, it also provides operating features which have never been seen before in audio equipment designed for home, such as fast access to any track on the disc, very simple programming and armchair control.

Please read this manual thoroughly. It will explain the features and operation of your CD Player and help to ensure a trouble free installation. Please unpack your CD Player carefully. We recommend that you save the carton and packing material, as they will be helpful should you ever need to move your unit or return it for service.

Your CD Player is designed to work in a horizontal position and it is important to allow at least two inches of space behind the unit for adequate ventilation and for the cables. To avoid damage, never place the unit near

SAFETY INFORMATION

This CD player is designed to operate on 220-240 Volts 50Hz AC or 110-120 Volts 60 Hz AC. Normally the equipment is supplied with a mains lead with a fitted 3 pin plug suitable for the country it is to be used in. If the plug needs to be changed, please follow the instructions below.

PLUG FITTING INSTRUCTIONS

The wires in the mains lead are coloured in accordance with the following code:

Blue	-	Neutral
Brown	-	Live
Green / Yellow	-	Earth

In the UK the wires must be connected to the terminals in the plug as follows:

Blue	-	N or Black
Brown	-	L or Red
Green / Yellow	-	E or Earth

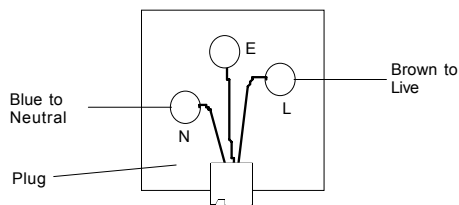

NOTE

1. If a 13-amp plug is used, in the UK it must be fitted with a 3 Amp fuse.
2. If a 3-pin plug with earthing contact is used, the Green/Yellow wire must be connected to the E terminal.
3. As with all electrical equipment, it is recommended that the mains plug is removed from the wall socket when not in use.

TO ACHIEVE MAXIMUM PERFORMANCE FROM YOUR CD PLAYER:

1. **Install** the equipment in a location which is relatively free of moisture and dust, and which is well ventilated.
2. Avoid installing the equipment in a location exposed to direct sunlight or extreme heat (such as above a heater or radiator).
3. The equipment may not be able to perform at its best in an extremely cold or hot environment. Do not attempt to use below 41°F/5°C or above 95°F/35°C.
4. Always **handle discs** with clean hands. Avoid using scratched discs..
5. Keep this manual in a safe place for future reference.
6. Do not attempt to clean the CD player or CD discs with chemical solvents, as this may cause irreparable damage. Use a clean, dry cloth, or specially designed cleaning materials for discs.
7. If the CD player malfunctions, **do not open the unit and attempt to repair it yourself.** This is a highly technical product and requires specialist service - return it to your dealer.
8. Use **batteries** (2 x AAA) of the same type in the remote control handset. The use of odd or different type cells will affect its

UK ONLY: FOR ADDED SAFETY, WHEN CONNECTING THE AC MAINS LEAD TO A 3 PIN PLUG USE A 3A FUSE APPROVED BY ASTA TO BS1362 - WITH  MARK

SAFETY WARNINGS

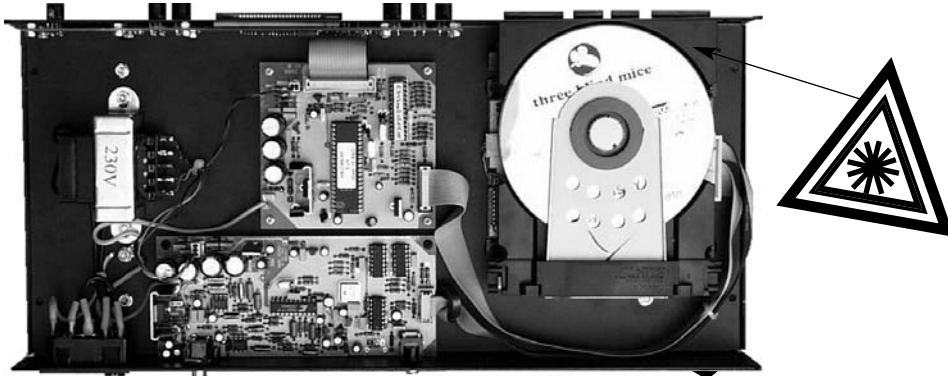

CAUTION!
Invisible laser radiation
when top cover is
removed.

CAUTION
PERFORMING
ADJUSTMENTS OR
PROCEDURES OTHER
THAN THOSE SPECIFIED
HERE MAY RESULT IN
HAZARDOUS EXPOSURE.

THE CD PLAYER SHOULD
NOT BE REPAIRED BY
ANYONE EXCEPT
QUALIFIED SERVICE
PERSONNEL.

Class 1 Laser Product

SPECIFICATION

Power requirements	AC 220-240 V 50 Hz
Power Fuse rating	T 250 mA
or:	AC 110-120 V 60 Hz
	T 500 mA
Power consumption	16 Watts max
Frequency response	1 Hz - 20 kHz ± 0.5 dB
Output level	2.2 V RMS at 1kHz, 0 dB
Output impedance	600 Ω , min load 10 kΩ
Laser type	Semiconductor ALGaAs
Wavelength	790 nm ± 25 nm
Light output (cw)	0.18 mW typical
Signal to noise ratio	better than 96 dB
Dynamic range	better than 100 dB
Number of channels	2
Total harmonic distortion	< 0.01% at 1 kHz, 0 dB
Dimensions	420 x 60 x 200 mm

OTHER FEATURES

1. Infra-red remote control.
2. High precision **24 bit**, $\Delta\Sigma$ digital to analogue conversion.
3. 128 Fs filter.
4. 3-beam optical laser pick up.
5. 16 program memory.
6. LCD display - back lit green.
7. Shuffle function (random selection).
8. Repeat facility.
9. Intro scan facility.

Note: *The specification and design are subject to change for improvements without notice.*

NOTE

The equipment has been tested and found to comply with the limits for a Class B digital device, pursuant to Part 15 of the FCC Rules. These limits are designed to provide reasonable protection against harmful interference in residential installations. This equipment generates and can radiate radio frequency energy and if not installed and used in accordance with the instructions may cause interference to radio communications. However, there is no guarantee that interference will not occur in some instances. If this product causes interference to radio or television reception, which can be determined by turning the equipment off and on, try to correct this by one or more of the following measures:

- Reorient or relocate the receiving antenna.
- Increase the separation between the equipment and the radio or TV receiver.
- Connect the equipment into a mains outlet on a circuit different from that to which the receiver is connected.
- Consult the dealer or an experienced radio/TV technician.

CONNECTING THE COMPACT DISC

CAUTION

- u Before connecting or disconnecting a unit from your audio system, make sure that you switch off the power to each component.
- u Ensure that you make the correct connections, paying attention to the **L** (left channel) and **R** (right channel) marks. Plug in the cable securely. Loose connections will result in unsatisfactory sound reproduction or noise problems.
- u If this unit interferes with the tuner, switch it off during tuner operation.

1. LINE OUT SOCKETS

Connect one end of the interconnect cable to the unit's **AUDIO OUTPUT** sockets and the other end to the sockets labelled **CD** or **AUX**, or to other line inputs on the amplifier. Do not connect it to the amplifier's **PHONO** input if a phono circuit is installed.

2. DIGITAL OUTPUT

This output enables you to connect the CD player to a stand-alone D to A converter in order to change the signal into a stereo analogue one. The digital output of the CD43 mk2 can be accessed via the co-axial SPDIF socket on the rear panel.

3. AC POWER SOCKET, IEC TYPE

220V-240 V AC or 110V-120 V AC

4. AC POWER CORD

After completing the installation and all connections, make sure that the **POWER** switch on the front panel of the unit is set to **OFF**. Then plug the power cord into a live AC outlet.

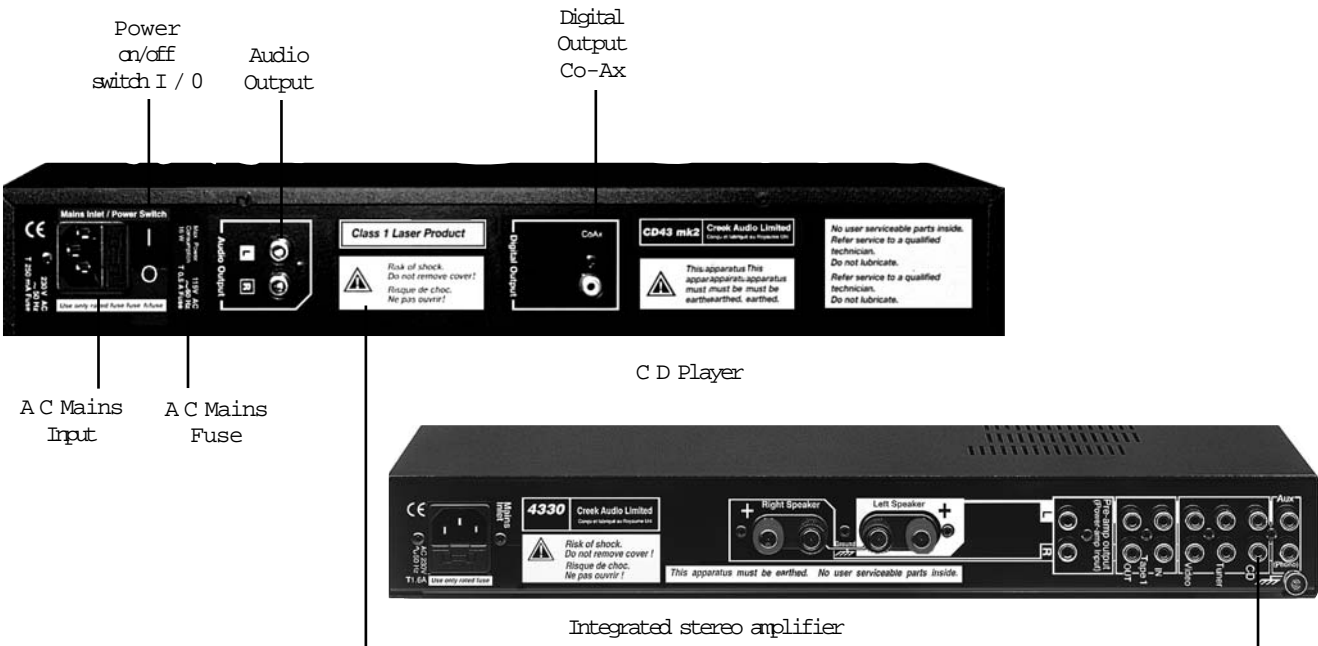

WARNING

UNAUTHORISED RECORDING OF COPYRIGHT MATERIAL MAY VIOLATE APPLICABLE COPYRIGHT LAWS. THE DISTRIBUTOR ASSUMES NO RESPONSIBILITY FOR THE UNAUTHORISED DUPLICATION, USE OR OTHER ACTS, WHICH INFRINGE UPON THE RIGHTS OF COPYRIGHT OWNERS.

EXPLANATION OF CONTROLS

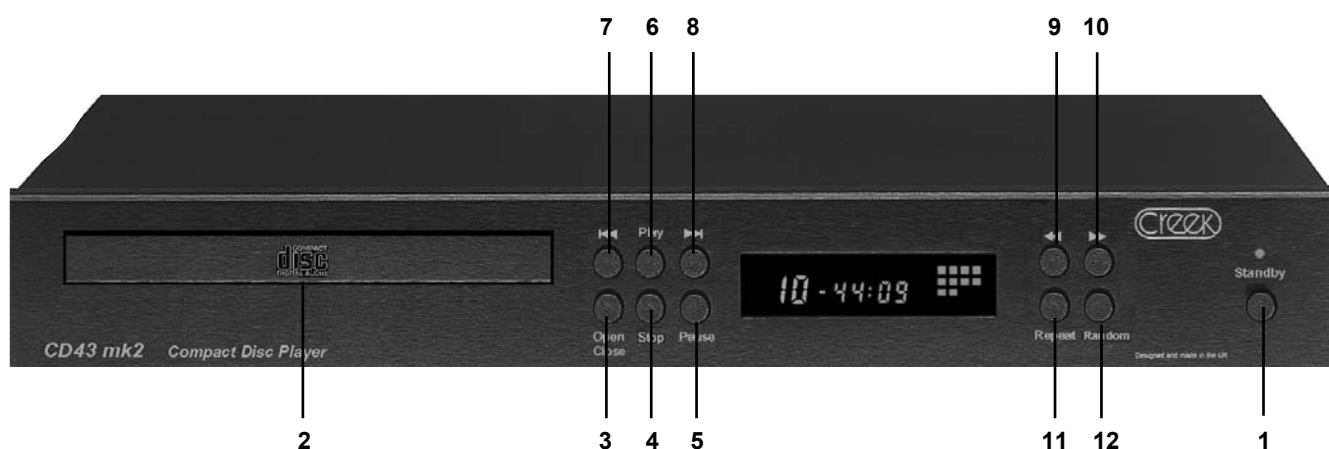

MAIN UNIT

- | | |
|----------------------|------------------------|
| 1. STANDBY button | 7. SKIP BACK button |
| 2. Disc Tray | 8. SKIP FORWARD button |
| 3. OPEN/CLOSE button | 9. SCANBACK button |
| 4. STOP button | 10. SCANFORWARD button |
| 5. PAUSE button | 11. REPEAT button |
| 6. PLAY button | 12. RANDOM button |

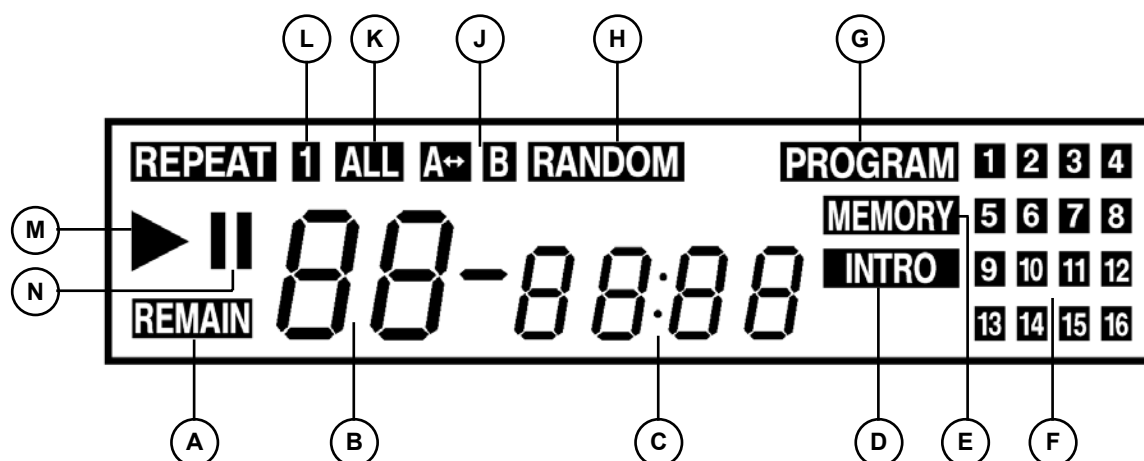





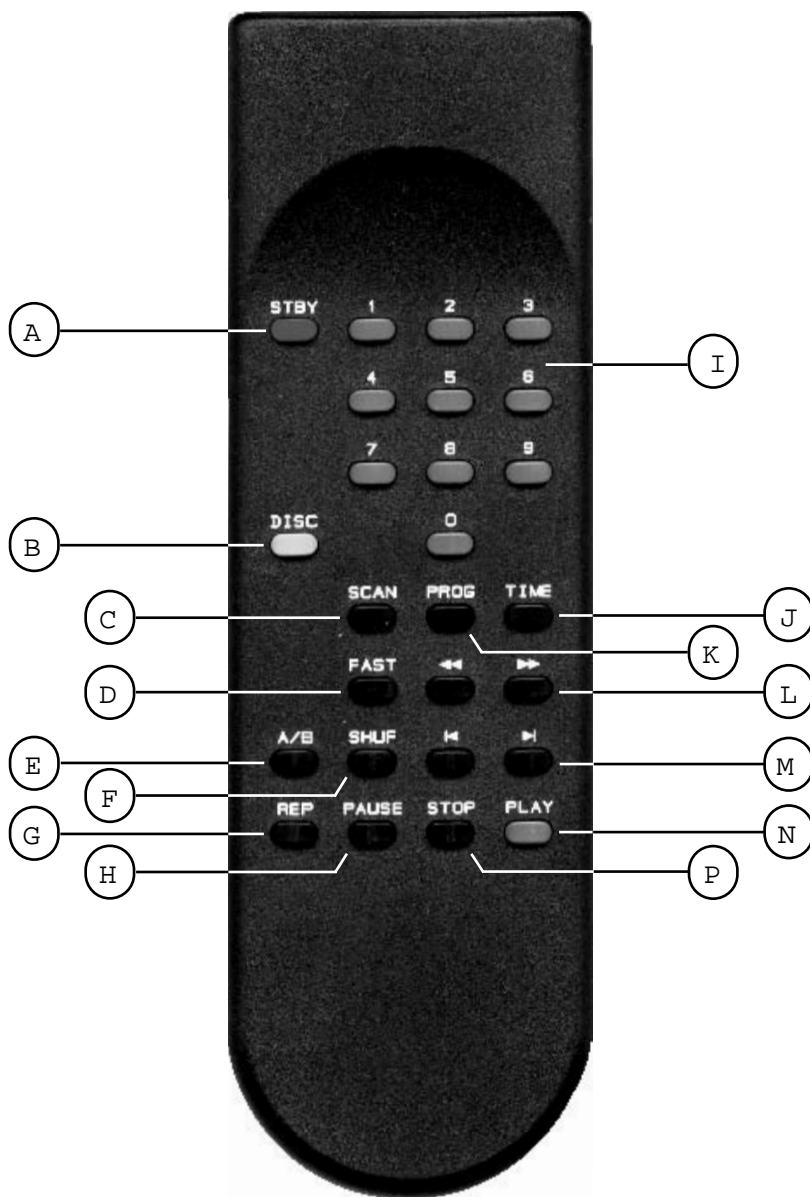

DISPLAY WINDOW

- | | |
|--------------------------------|------------------------------------|
| A. REMAINING time indicator | H. RANDOM / SHUFFLE PLAY indicator |
| B. TRACK NUMBER display | J. REPEAT A ↔ B indicator |
| C. PLAYING TIME display | K. REPEAT ALL indicator |
| D. INTRO / SCAN indicator | L. REPEAT 1 indicator |
| E. MEMORY indicator | M. PLAY indicator |
| F. CALENDAR track display | N. PAUSE indicator |
| G. PROGRAM indicator | |

EXPLANATION OF CONTROLS



REMOTE CONTROL UNIT

- | | |
|---|--|
| A. STANDBY STBY | H. PAUSE PAUSE |
| B. OPEN/CLOSE DISC  | I. NUMERICAL track selection 0-9 |
| C. INTRO SCAN | J. REMAINING TIME TIME |
| D. FAST FAST | K. PROGRAM PROG |
| E. REPEAT A ↔ B A/B | L. SEARCH  back &  forward |
| F. SHUFFLE / RANDOM PLAY SHUF | M. SKIP TRACK  back &  forward |
| G. REPEAT REP | N. PLAY PLAY  |
| | P. STOP STOP  |

COMPACT DISCS

HANDLING THE DISCS

This unit has been designed to play Compact Discs bearing the identification logo shown below. DVD discs cannot be played.



- u Always place the CD in the disc tray with the label facing up. CD's can only be played on one side.
- u To remove a CD from its storage case, press down on the centre of the case and lift the disc out, holding it carefully by the edges.

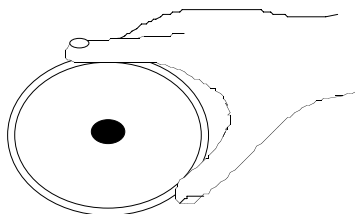

- u Fingerprints and dust should be carefully wiped off the CD's signal surface (glossy side) with a soft dry cloth. Unlike a conventional record, the CD has no grooves to collect dust and microscopic debris, so gently wiping it with a soft dry cloth should remove most particles.
- u Wipe the disc in a straight motion from the inside out. Small dust particles and stains will have absolutely no effect on reproduction quality.
- u Never use chemicals such as record sprays, antistatic sprays or fluids, benzine or thinners to clean a compact disc. Such chemicals would irreparably damage the surface.
- u Store the discs in their cases when not in use to avoid serious scratches which could cause the laser pickup to skip.
- u Do not expose the discs to direct sunlight, high humidity, or high temperatures for extended periods. Long exposure to high temperatures can warp the discs.
- u Do not stick paper or write anything with a ballpoint pen on the disc surface.

LOADING DISCS

1. Switch the power on at the back of the unit. Press the **STANDBY** button on the front panel or **STBY** on the remote handset.
2. Press the **OPEN/CLOSE** button on the front or **DISC** on the handset. The disc tray will open. If the disc tray gets jammed while opening, it will stop and close automatically.
3. When the disc tray has opened fully, take a normal size (12 cm) disc from its case and place it carefully in the tray with the label facing up. To play an 8 cm single place it in the inner groove of the tray with the label facing up.

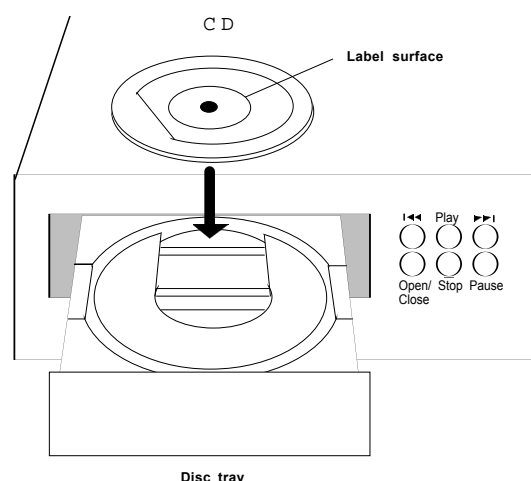

NOTE: Only load one disc at a time. The side opposite the label is the signal side. Handle the disc carefully to avoid leaving fingerprints on its surface.

4. To close the disc tray, press the **OPEN/CLOSE** button (**DISC** button) again or gently push the tray in.

When the tray is fully closed, with a correctly loaded disc, the disc will start turning automatically and the TOC (table of contents) will be read. The disc will then stop and the TOC will be displayed, i.e. the total **number of tracks** on the disc and the total **playing time** of the disc. The **calendar** track indicator will also light up and the CD player will be ready to play.

NOTE: If after you load the disc you press the **PLAY** button to close the tray, the disc will automatically start playing from the beginning of track one.

REMOVING THE DISC

The disc tray can be opened at any time by pressing the OPEN/CLOSE button. Remove the disc only after the tray has fully opened.

CAUTION

- u Do not put anything except a Compact Disc into the tray. Foreign objects can damage the mechanism. DVD's will not play.

- u Do not force the tray by hand during the opening and closing operations.
- u To avoid dirt and dust entering the mechanism, keep the disc tray closed when the CD player is not in use.
- u Never load two discs into the disc tray.

CONTROL AND OPERATION

This section describes the CD player's controls in the order in which you would normally use them. Follow the instructions step-by-step and you will easily master the operation of the unit.

POWER

The CD43 mk2 is equipped with a mains On/Off switch on the rear panel next to the power cord. The marking on the panel clearly shows that **1** is on and **0** is off.

Switching on the power from the rear panel automatically places the CD43 mk2 in **Standby** mode. To wake it up, press the **STANDBY** button on the front panel or **STBY** on the remote handset. The LED indicator will alternate from yellow colour in **Standby** mode to green when ready to play. The display will also illuminate when ready to play. If the drawer is open, it will close automatically when Standby is pressed.

To wake up the CD43 mk2, press any button. However, the disc drawer can be opened immediately from Standby.

again to close the disc tray.

N.B. If you get a message **dISC** on the display when the disc tray is fully closed, this means that the disc is improperly loaded (most likely upside down). To check, open the disc tray again and reload the disc correctly.

If the disc tray gets jammed while closing, the tray will stop and open automatically. If this happens check the disc tray and reload the disc correctly.

5. When the disc is loaded correctly the the player will spin the disc to read the TOC (table of contents). This will tell the player how many tracks are recorded on the disc and how long they are. Depending on the number of tracks and the method of recording the information, the TOC read can vary from 3 - 10 seconds or more. Until this has been achieved, no other function will work. When the TOC is correctly read the player will display the information.

NORMAL DISC PLAY

Before playing a disc, check the player's power cable and output cable connections.

1. Switch on the CD43 mk2 at the rear panel, a yellow LED will light above the power button.
2. Press the **STANDBY** switch on. The LED will turn green.
3. Press the **OPEN/CLOSE** or **DISC** button to open the disc tray and load the disc.
4. Press the **OPEN/CLOSE** or **DISC** button





For example:

There are 8 tracks on the disc. The total playing time is 48 minutes and 54 seconds. The player is set to play when required.

6. Press the **PLAY** button. The **PLAY** symbol will appear on the display. The disc will start

playing from the beginning of the first track.

You may also go straight to a specific track by using one of the SKIP buttons  or . In this case the disc will start playing the selected track when the PLAY button is pressed. The numeric keys on the remote handset allow direct access to the desired track.

- 7. At the end of the last track the CD will return to a waiting mode.

NOTES :

- u If the CD is deeply scratched or too dirty, disc play may not start. If an improperly centered disc is played, noise will be heard in the mechanism. Avoid using such discs.
- u Some discs of poor manufacture may not be readable or may skip, check another disc should this occur.
- u Some discs will take a long time to read the TOC if they have a lot of tracks, i.e. more than 20.

OPERATION

◆ STANDBY

When switching on from Standby, if there is no disc in the CD43 mk2, the display will show **no disc**.

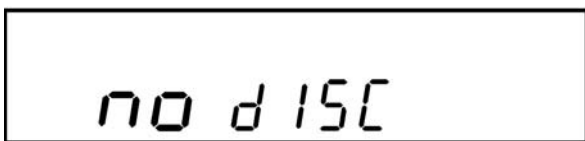

If there is a disc in the CD43 mk2, the track display will show **disc** until the TOC (table of contents) has been read.

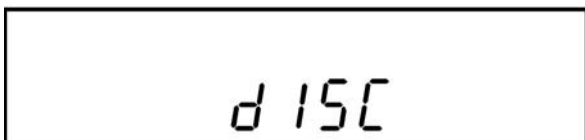

When the TOC has been read, the CD43 will display the information, i.e. the total **number of tracks** and total **playing time**.



◆ INSERTING A DISC

Press the OPEN/CLOSE button on the front panel or DISC on the handset, the disc tray will open and the OPEN sign will be displayed.



Insert the disc and press the OPEN/CLOSE or DISC button again to close the tray.

The disc will start spinning and the total number of tracks will be read. The disc will then stop and the display will show the **TOC** (table of contents), being the total **number of tracks** and the total **playing time**.



◆ TO PLAY A DISC

Press the PLAY button. The disc will start playing.

The track number 1 will be displayed, together with the PLAY ► symbol and the elapsed **time** of the track being played.

The calendar will show the total number of tracks on the disc and the symbol for track **1** will start flashing.



◆ TO 'STOP DISC PLAY

Press the **STOP** button. The disc will stop playing, the **PLAY** ► symbol will disappear and the **track** indicator will show the total number of tracks. The **time** indicator will display the total playing time.



◆ **TO PAUSE THE DISC PLAY**

Press the **PAUSE** button. The disc will stop playing at the current play position and the **PAUSE** || symbol will be displayed. The track number on the **calendar** display will continue flashing.



Press the **PAUSE** button again or press **PLAY** to resume disc play. The **PAUSE** || symbol will disappear.

CHECK THE DISK AND TRACK REMAINING TIME

(Remote control only)

During normal disc play, when the **TIME** button on the Remote control is pressed, the **REMAIN** symbol will light up and the remaining playing time of the track will be displayed.

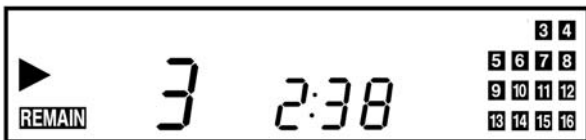

Pressing the **TIME** button twice will show the remaining playing time of the disc; the **REMAIN** symbol will still be displayed.

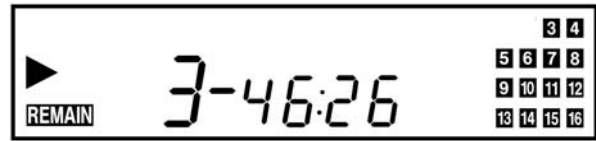

When the **TIME** button is pressed for the third time, the **time** indicator will return to the elapsed time of the track being played.

TO LISTEN TO A DESIRED TRACK

Press the **SKIP FORWARD** or **SKIP BACK** button to select a desired track. The track number of the selected track will be shown on the **track** display.

◆ **SKIP FORWARD TO THE NEXT TRACK**

To skip ahead to the beginning of track 5, for example, while track 4 is playing, follow the steps below:

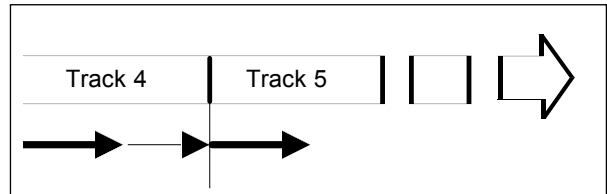

Press the **▶|1** button on the front panel, or the **▶|1** button on the remote handset once.

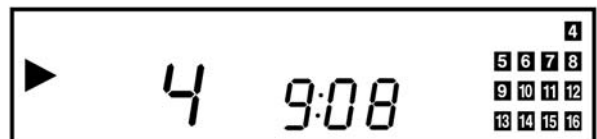

The player will skip to the beginning of the next track.

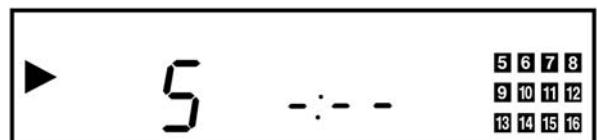

Disc play starts with track 5.

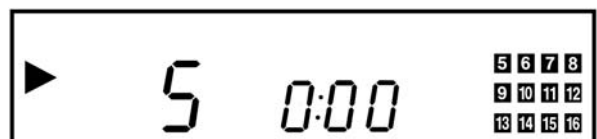

The CD player will skip ahead to the next track each time the or button is pressed.

Continuously pressing the or button makes the CD player skip ahead through the disc, track by track, until you reach the desired place. The CD player can be advanced to the last track in this way. When the last track is reached, the CD player will return back to track 1.



Disc play will start from track 3.

◆ 'SKIP BACK TO THE PREVIOUS TRACK

To skip to the beginning of track 3, for example, while track 4 is playing, follow the steps below:

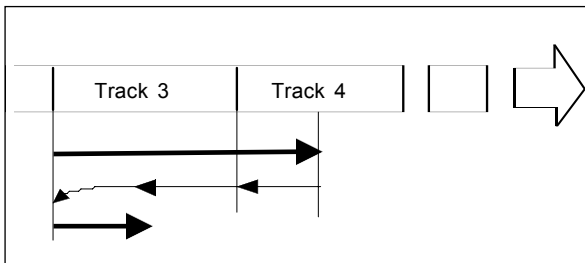

Press the button on the front panel, or the button on the remote handset twice.

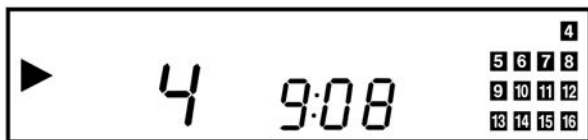

The player will skip to the beginning of the current track.

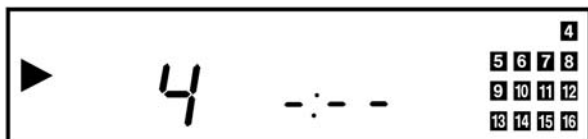

Press the or button again.

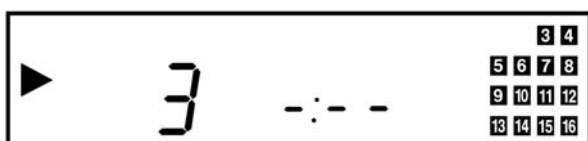

The player will skip to the beginning of the previous track.

◆ TO SEARCH QUICKLY FOR A PARTICULAR POINT OF A TRACK

During **PLAY** mode press and hold the ◀◀ or ▶▶ buttons for fast-forward and fast-back operation.

During **PLAY** mode:

When ◀◀ or ▶▶ button is pressed, the sound will be muted to about 1/4 of the normal volume level for the duration of the fast-forward or fast-back operation.

During **PAUSE** mode:

Pressing ◀◀ or ▶▶ buttons will release the pause mode and the search will continue normally with a muted sound.

During the ◀◀ or ▶▶ operation, for the first few seconds the player will search slowly through the disc and then switch to searching fast.

◆ FAST SEARCH

(Remote control only)

Using the remote control only, the fast search can be enabled by pressing the **FAST** button before pressing the search ◀◀ or ▶▶ buttons.

◆ RANDOM / SHUFFLE PLAY

Use this feature to play tracks on a disc in a random order.

1. Press the **RANDOM** button on the front panel or the **SHUF** button on the remote handset.
2. Press the **PLAY** button. A track will be randomly selected and the disc will start playing.

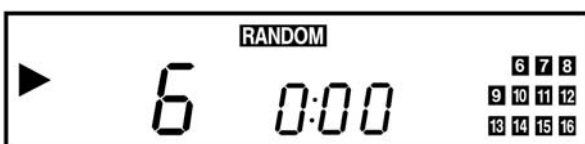

NOTE: When the **RANDOM / SHUF** button is pressed during play, the whole calendar is displayed and random play

starts at the end of the current track.

PROGRAMMED DISC PLAY

(Remote control only)

This feature allows you to play tracks in your preferred sequence.

It is not possible to program the CD player while the disc is playing. Press the **STOP** button first, then enter a program.

◆ ENTERING A PROGRAM

To program a desired sequence of tracks:

1. Select the first track using the ▶| ◀| or numeric buttons. Press the **PROG** button on the remote handset. The **MEMORY** indicator will illuminate and the track number will be displayed on the **calendar**. The first selected track is now stored in the memory.
2. Select the next track number using the ▶| ◀| or numeric buttons. Press the **PROG** button again - the second choice is now stored in the memory.
3. Repeat the steps above until all the desired tracks are stored in the memory. The complete programmed sequence is displayed on the **calendar**.

EXAMPLE

To play track 5, track 2 and track 8 in sequence:

Enter the first choice by selecting track 5 using the ▶| or numeric button. Press the **PROG** button to store the first choice. Track **5** is now stored.

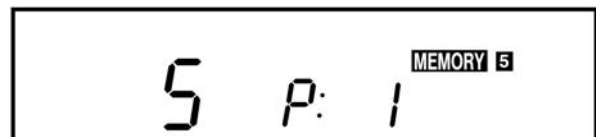

The **time** display will toggle between **P: 1** and the playing time of the selection.

Enter the second choice - track 2 using the ◀| or numeric button. Press the **PROG** button to store the second choice. Track **2** is also stored.

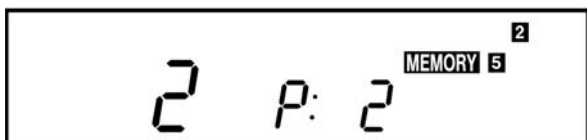

Enter the third choice - track 8 in the same way. Press the **PROG** button to store the third choice.

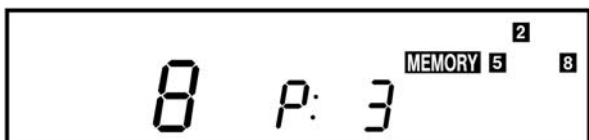

Press the **PLAY** button. The first programmed track will start playing.

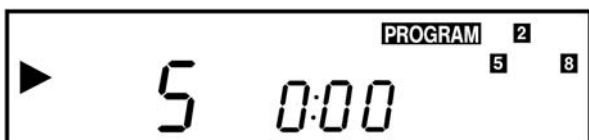

◆ LISTENING TO A PROGRAMMED SEQUENCE

1. Press the **PLAY** button. The **PLAY** ▶ symbol will be displayed.
2. The disc will start playing the first programmed track.

NOTE: When playing a programmed sequence, after each track the number of tracks displayed on the *track calendar* will automatically decrease.

3. After the programmed sequence has finished playing, the *track* display and the *time* display will show the number of tracks played and the total playing time.

◆ CHANGING THE PROGRAM

1. Press the **STOP** button if the disc is playing.
2. Press the **PROG** button. All track numbers stored in the memory will be displayed on the *track calendar*.

You can modify the program by entering new track numbers.

◆ CLEARING THE MEMORY

1. Press the **STOP** button if the disc is

playing.

2. Press twice the **OPEN/CLOSE** button on the front or **DISC** button on the handset. This will clear the memory and the player will be ready to play again.

NOTE: The memory will be cleared if the power is switched off on the rear panel.

REPEAT DISC PLAY

Use the **REPEAT** button to repeat the disc play of a track, all tracks on the disc, or a programmed sequence of tracks.

◆ **REPEAT ONE TRACK**

Make sure that the **PROGRAM** function has not been selected.

1. Press the **REPEAT** button once and the **REPEAT 1** message will appear.
2. Select the desired track using the **▶▶** **◀◀** or **▶** **◀** or numeric buttons. The track number will appear on the **track display**.
3. Press the **PLAY** button. The **PLAY ▶** symbol will be displayed and the selected track will start playing.

NOTE: You can also select **REPEAT** mode while the desired track is playing.



4. At the end of the track the CD player will automatically return back to the beginning. The track will continue to repeat until the **STOP** button is pressed.
5. To cancel **REPEAT 1** press the **REPEAT** button twice, to toggle pass **REPEAT ALL** and back to normal **PLAY ▶** mode.

◆ **'REPEAT ALL TRACKS ON THE DISC**

1. Press the **REPEAT** button twice and the **REPEAT ALL** message will appear.
2. Press the **PLAY** button and the disc will start playing.

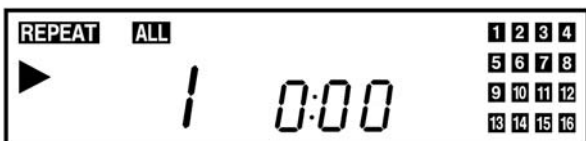

3. At the end the last track the CD player will automatically return to the beginning of the first track. The repeat play will continue until the **STOP** button is pressed.

NOTE: You can also select **REPEAT ALL**

mode while the disc is playing. At the end of the last track the disc will automatically return to the beginning of the first track and will continue playing until **REPEAT ALL** is cancelled.

5. If the **REPEAT** button is pressed again, the **REPEAT ALL** message will disappear and normal play will resume.

◆ **REPEAT A PROGRAMMED SEQUENCE OF TRACKS**

1. Enter a program.
2. Press the **REPEAT** button twice and the **REPEAT ALL** message will appear.
3. Press the **PLAY** button, the **PLAY ▶** symbol will be displayed and the programmed sequence will start playing.
4. All programmed tracks will continue playing in order until the **STOP** button is pressed.
5. If the **REPEAT** button is pressed once more, the **REPEAT ALL** message will disappear and normal play will resume.
6. At the end of the last track, the CD player will stop and the **PLAY ▶** indicator will disappear.

◆ **'A ↔ B DISC PLAY**

(Remote control only)

Use to repeatedly play a portion of the disc, from point **A** to point **B**.

1. Press the **PLAY** button.

Go to the starting point of your selection using **▶** **◀** and **◀◀** **▶▶** keys and press the **A/B** button.

The **REPEAT A ↔ B** message will appear, with the letter **B** flashing, and point **A** will be stored in the memory.



2. Press the **A/B** button again at the end point of your choice.

The letter **B** will stop flashing and point **B** will be stored in the memory. The segment

TROUBLESHOOTING GUIDE

If you have followed the instructions, and are having difficulty operating your compact disc player, please use the simple guide below to help you solve the problem. Here we have listed the most common hiccups experienced by the users, which we hope will be of some help.

Locate the SYMPTOM in table below and then check the corresponding POSSIBLE CAUSE and CORRECTIVE ACTION to remedy the problem.

SYMPTOM	POSSIBLE CAUSE	CORRECTIVE ACTION
No power when the power switch is ON.	Poor power plug connection at the AC outlet. Fuse in the mains plug has blown. CD player is in standby mode.	Insert the power plug firmly into the AC outlet. Replace the fuse in the mains plug. Press Standby button.
Disc play does not start.	The disc is loaded upside down. The disc is too dirty. A DVD is being used.	Reload the disc with the label side up. Clean the disc. Replace the DVD with a CD disc.
No sound.	Improper output cable connections. Improper amplifier operation.	Connect the output cable properly. Make sure that the amplifier controls are set properly.
Sound skips.	Damaged, faulty or dirty disc. The CD player is subject to vibrations or physical shock.	Clean or replace with a new disc. Change the location of the player.
Programmed sequence will not play.	The CD player is in the normal disc play mode.	Press the STOP button and then program the tracks.
Humming noise.	Loose cable connections.	Make sure that all audio plugs are connected firmly.
Remote handset will not function.	Batteries low.	Replace the batteries .

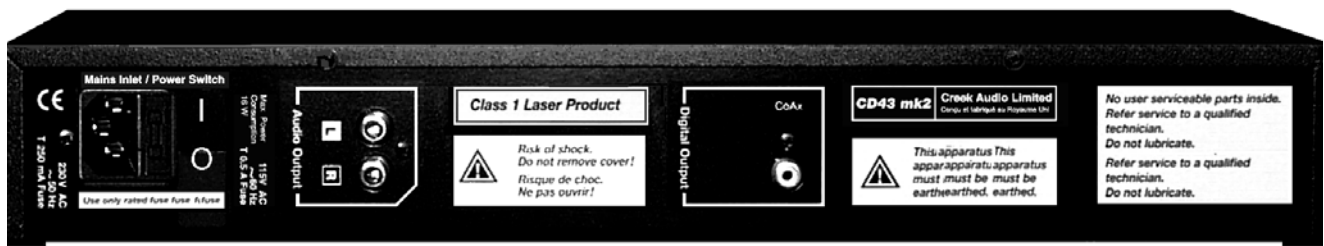

**2 Bellevue Road, Friern Barnet,
London N11 3ER, England**

Tel: + 44 + (0)20 - 8361 4133

Fax: + 44 + (0)20 - 8361 4136

E-mail: info@creekaudio.co.uk

Internet: www.creekaudio.co.uk

*Creek Audio Limited reserves the rights
to modify or change the specification of
its products without notice.*